



**Northeast Junior Olympic Regatta**  
*July 21 – 22, 2009*  
**Host: Northeast Harbor Sailing School**  
**Venue: Sea Street Marina**  
**Northeast Harbor, ME**



**SAILING INSTRUCTIONS**

**1. RULES**

This regatta will be governed by the rules as defined in the Racing Rules of Sailing 2009-2012.

**2. NOTICES TO COMPETITORS**

Notices to competitors will be posted on the official notice board located inside the Regatta Tent.

**3. SIGNALS MADE ASHORE**

Signals made ashore will be made verbally by the PRO.

**4. CHANGES TO THE SAILING INSTRUCTIONS**

Any Change to the Sailing Instructions will be posted prior to 0900 on the day it will take effect.

**5. SCHEDULE**

A mandatory attendance competitors' meeting will be held at 1000 on Tuesday. All coaches and sailing instructors must attend a safety meeting at 0930 on Tuesday and 0900 on Wednesday.

Monday, July 20	1600-1900	Early Arrival & Late Registration
Tuesday, July 21	0800-0930	Late Registration & Check-In
	0930	Coaches' and Safety Boat Meeting
	1000	Competitors' Meeting
	1030	Harbor Start
	1130	First Warning, Multiple Races to Follow
	1730	Dinner and viewing of movie "Morning Light"
Wednesday, July 22	0900	Coaches' and Safety Boat Meeting
	0930	Harbor Start
	1100	First Warning, Multiple Races to Follow (No Warning Signal after 1500)
	1600 (approximately)	Awards Presentation

## 6. RACING AREA

The racing area will be the waters of Northeast Harbor and the surrounding bays.

## 7. COURSES and MARKS

Green Fleet Optis will have Green Balls for turning marks and a large yellow inflatable buoy for a start/ finish mark. The course shall be a modified port triangle with the start/ finish line near the center.

Championship Optis will have Orange Balls for turning marks and a large yellow inflatable buoy for a start/ finish mark. The course shall be a modified windward, leeward with gates at the top and bottom of the course and a start/ finish line near the center.

Lasers and 420s will have VERY LARGE Orange and Yellow tetrahedron inflatable turning marks and a large round yellow inflatable buoy for a start/ finish mark. The course shall be a modified windward, leeward with gates at the top and bottom of the course and a start/ finish line near the center.

The courses will be described verbally during the competitors' meeting, posted on the official notice board and are diagramed in appendix 1.

## 8. STARTING AND FINISHING LINES; STARTING SYSTEM

The starting and finishing lines will be between the RC boat staff and the adjacent yellow inflatable mark on its port side.

Appendix S - Sound-Signal Starting system will be used for all classes.

## 9. PROTESTS

Protests shall comply with the Rules Part VI. Protest forms are available at the registration table and should be completed and submitted to the registration table within 20 minutes of the last boat to come out of the water at the ramp. Hearings will be held as soon as possible.

## 10. SCORING and ROTATION

The Low Point System of Appendix A will apply. All scores will count if five or fewer races are completed. If six or more races are completed a boat's worst score will be discarded. Three races shall constitute a series. As many races as possible will be run with no races starting after 1500 on Wednesday, July 22. This amends the NOR which limited the number of races per fleet to 9.

## 11. SAFETY GATE and CHECK IN

All boats shall sail through a gate with two inflatable yellow buoys on their way to the race course each day and on their way back into Northeast Harbor at the conclusion of sailing. All boats are also REQUIRED to check in with their course RC boat upon arrival and notify them if you leave the race course before the end of that day's racing.

All competitors shall wear a Coast Guard approved personal floatation device with a safety whistle attached, properly fastened at all times including launching and when sailing.

## 12. COACHING AND SAILING INSTRUCTORS

Coaches and Instructors must attend both morning briefings. Your cooperation and assistance with all competitors who need support is required. Coach boats shall display a purple flag while in the race area each day.

## 13. TRASH AND WATER BOTTLES

All competitors are reminded that this event is a CLEAN REGATTA. Absolutely no trash should be discarded into the water. Safety boats on your race course are designated with a red flag and they, as well as any coach boat, will be happy to dispose of any trash for you. All water bottles should be saved and refilled for your later use.

## 13. QUESTIONS

Questions will be answered at the competitors' meeting.

## 14. RACE COMMITTEE and VHF CHANNELS which they will operate on.

Opti Red White and Blue PRO- Jonathan Foot CH 71

Opti Green PRO- Martha Somes CH72

Lasers and 420s PRO- Fran Charles CH 73

### Appendix 1

#### Green Fleet Course

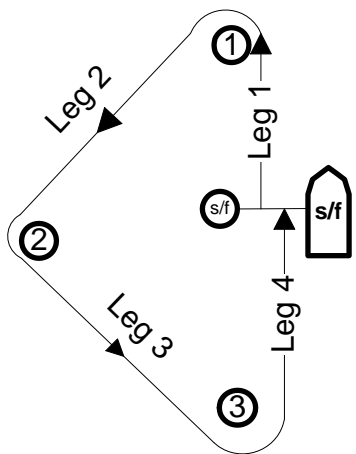

#### Opti R,W & B and 420 / Laser Course

